

Model No. 881042 IP140S3-TE
 881051 IP140S12-TE
 881030 IP200S25-TE
 881031 IP250S20-TE

Yamada

TOTE TYPE INK PUMPS

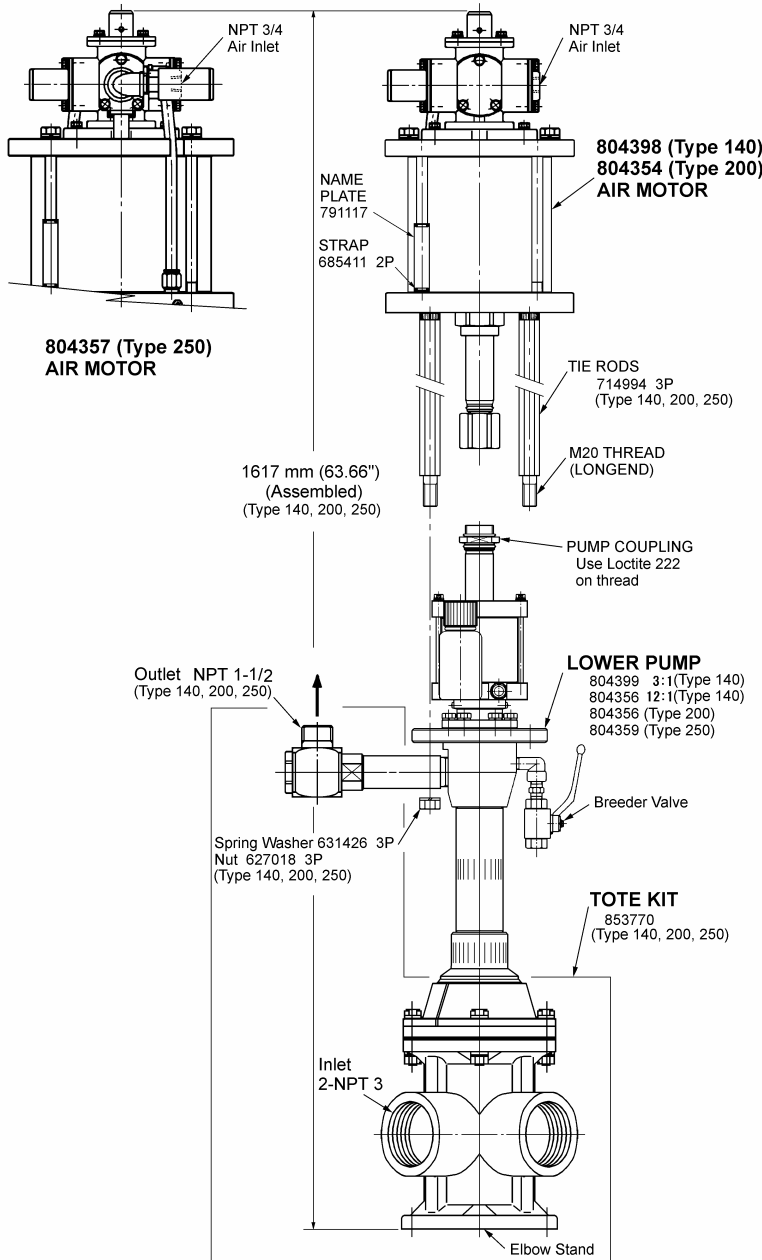

⚠ WARNING

- When air is supplied to the pump or when the inner pressure is not decreased completely, never put your hand closer to the inlet port of the pump.
- Do not operate with combustible gas.

YAMADA AMERICA, INC.

955 E. ALGONQUIN RD. ARLINGTON
 HEIGHTS, IL 6005, U.S.A
 PHONE: 1-847-631-9200
 FAX: 1-847-631-9273
<http://www.yamadapump.com>

Manufactured by YAMADA CORPORATION

INTERNATIONAL DEPARTMENT
 1-1-3 MINAMI-MAGOME,
 OHTA-KU, TOKYO 143-8504, JAPAN
 PHONE: (81) 3-3777-0241
 FAX: (81) 3-3777-0584

TOTE Model	Pump Model	Ratio	Air motor Size In.(mm)	Air motor Model	Maximue Discharge Pressure PSIG(Bar)	Output Per Cycle Cu.In.(mL)	Stroke length In.(mm)	Minimum Air Supply Hose In.(mm)	Maximum Operating AirPressure PSIG(Bar)	Operating Temperature °F(°C)	Noise Max dB(A)	Weight Lbs(kg)
881042	853787	3:1	5.5(140)	804398	305(21)	82.4(1350)	5.9(150)	½(12.7)	100 (7)	32° to 176° (0° to 80°)	85	181(82)
881051	853682	12:1	5.5(140)	804398	1200(84)	19.5(320)	5.9(150)	½(1.27)	100 (7)		86	154(70)
881030	853767	25:1	8(200)	804354	2500(175)	19.5(320)	5.9(150)	½(12.7)	100 (7)		83	163(74)
881031	853768	20:1	10((250)	804357	2000(140)	39.7(650)	5.9(150)	½(12.7)	100 (7)		83	212(96)

NOTE: Pump should be installed upright for operation.

CONFIGURATION OF THE AIR MOTOR AND THE LOWER PUMP

- The air motor and the lower pump are fixed with a tie-rod and coupling as shown on the previous page.
- The appearance difference between a Model 200 and a Model 250 is the number of exhaust ports: a Model 200 is equipped with one port while a Model 250 has two ports.
- By installing special manifold in the lower pump it changes into the TOTE style ink pump.

OPERATING PRECAUTIONS

- Operators or maintenance persons must read the instruction manual thoroughly before operating or maintaining the pump. They must not operate the pump until they understand the descriptions of the manual completely.
- Before maintaining or cleaning the pump, be sure to shut off air supply and release the inner pressure from the pump.
- Replace a component of the pump with the corresponding Yamada genuine part only.
- When cleaning the pump with highly volatile liquid, or when pumping up highly volatile liquid with the pump, ventilate your site well to prevent any fire from breaking out.
- Keep solution far away from any heat source or fire. Fasten the cap of the solution bottle firmly if you do not use it immediately.

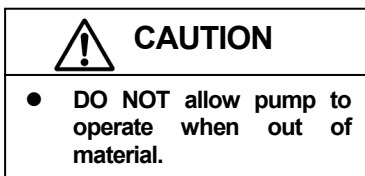

- Be sure to use only ISO VG10 general-purpose spindle oil (additive free) for the solvent cup. If you happen to use another type of oil, it may damage or swell the acrylic resin cup. To clean the cup, do not use wash oil or any other solvent either.
- Install a set of three parts (filter, regulator and lubricator) at the primary air line of the pump. However, if you install this set at the main air supply line when you use two or more pumps, oil may be mainly supplied to the farthest pump without supplying any oil to the other pumps. Therefore, install this set for each air line go to the each pipe from main air line in such a case. Using turbine oil (Additive free ISO grade 32) for the lubricator.
- Select the device applicable to the performance of the primary air pipe of the pump:
 - ◇ Recommended air flow:
 - Type 140 3:1 28 cfm or higher [800 L/min (ANR) or more]
 - Type 200 25:1 53 cfm or higher [1500 L/min (ANR) or more]
 - Type 250 20:1 106 cfm or higher [3000 L/min (ANR) or more]

DESIGN OF THE GLAND SEAL

- Ink is stuck to the exposed pump plunger, and dries up, so it causes the gland seal of the pump to be worn out.
- To prevent the gland seal from being worn out as much as possible, the pump plunger is designed so that it can operate in solution.
- If you replace the impure solution with new solution regularly, the plunger and the gland seal can always slide each other well.

PUMP PRIMING

- The lower pump and elbow stand has to be filled with ink before the pump starts ejecting ink.
- Elbow stand inside can draw out air by removing the plug.
- When you open the ink valve of the pump ejecting line slowly, the sealed air is pushed by ink to fill the lower pump with ink.
- If the pump ejects no ink repeatedly while it is operating, open the bleeder valve a little to blow the sealed air.
- After checking that ink is ejected, close the bleeder valve.
- The pump was tested with soybean oil at the factory. A little soybean oil remains in the pump to protect components of the pump during storage or transport of the pump. To prevent ink from being contaminated with soybean oil, clean the pump thoroughly before using it.

APPEARANCE AND DIMENSIONS

IP140S3-TE: 881042
 IP140S12-TE: 881051
 IP200S25-TE: 881030

IP250S20-TE: 881031

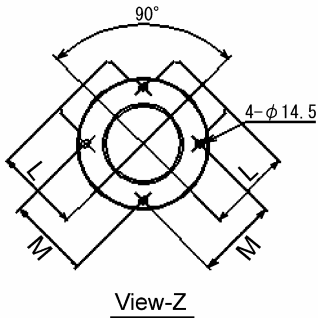
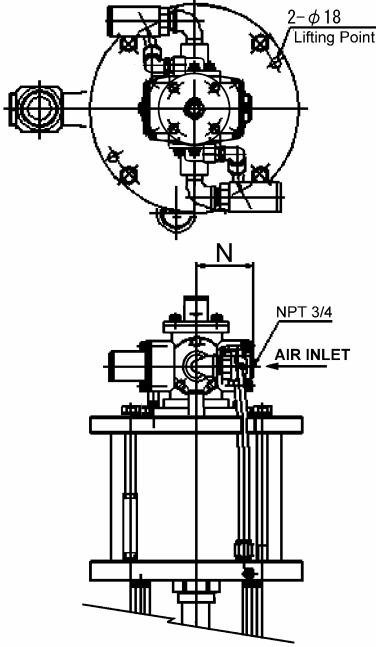
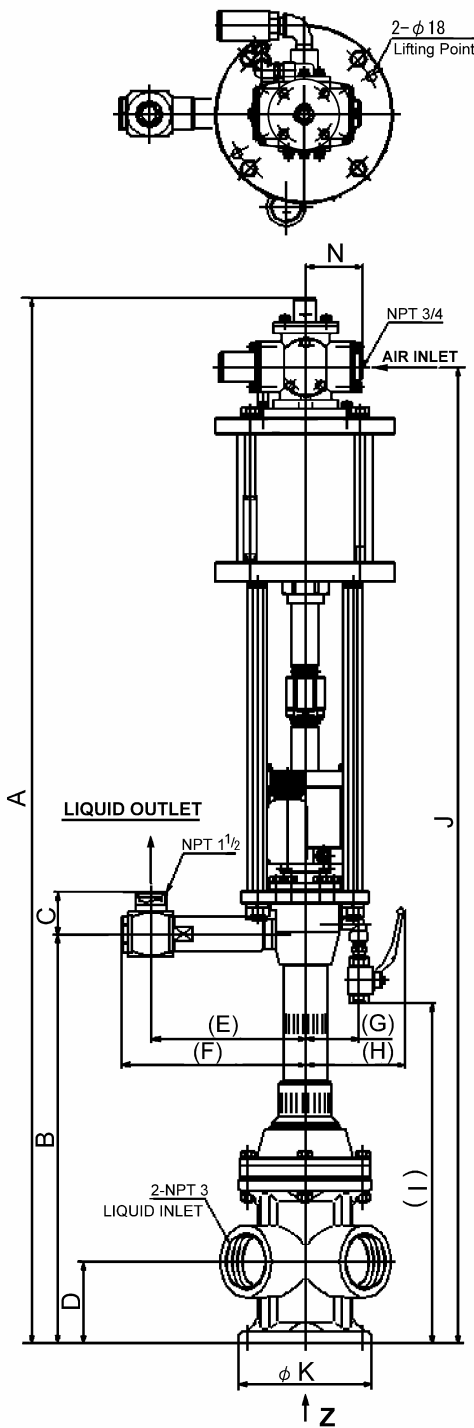

(mm)

Model No.	A	B	C	D	E	F	G	H	I	J	K	L	M	N
881042	1617	626	65	127	256	302	109	180	519	1509	205	130	125.4	88
881051	1617	629	65	127	237	283	92	163	522	1509	205	130	125.4	88
881030	1617	629	65	127	237	283	92	163	522	1509	205	130	125.4	88
881031	1617	629	65	127	241	287	97	167	519	1509	205	130	125.4	88

FILLING THE OIL CONTAINER

The pump is equipped with the fluid containers that prevent any fluid from being stuck to the plunger rod or gland packing. Follow the procedure below to fill the pump with oil appropriate for ink.

- A pail of off-the-shelf general-purpose spindle oil (additive-free ISO grade 10) is required.
- Attach the dedicated oil supply hand pump onto the pail.
- Connect the mouthpiece of the hose to the lower coupler of the solvent cup, and move the handle of the oil supply hand pump up and down to supply oil to the container until approximately half of the container is filled with oil.

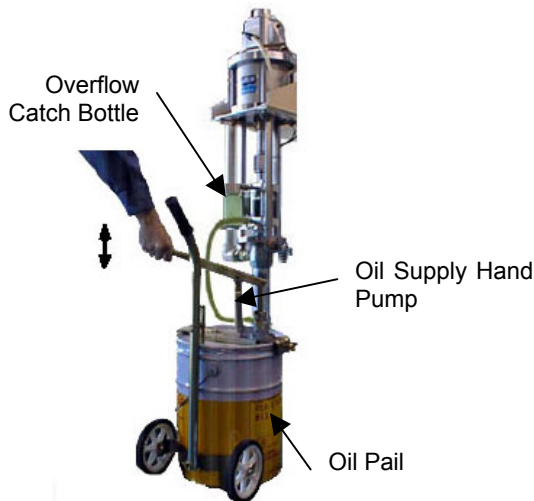

WARNING

- All packing used for the pump is NBR type. Do not use any solvent that corrodes NBR type packing.
- Be sure to attach the overflow catch bottle to the pump. When packing is worn out and ink leaks, the internal pressure of the oil container increases. This may damage the container if you do not attach this bottle to the pump.
- Do not put any oil into the overflow catch bottle before attaching it to the pump. When ink leaks due to worn-out packing, ink cannot be released in the normal way and may gush out from the hole of the container top.

CAUTION

- When you use the ink supply pump for a long time, ink overflows mainly because the gland packing is worn out and then ink has accumulated in the collection container. This phenomenon indicates when to replace the gland packing with a new one. Check to see whether ink is accumulating in the catch bottle periodically.

SUCKING INK AND REMOVING AIR

- Close the valve of the delivery pipe and open the bleeder valve of the suction pump.
- Place a container that saves ink discharged by the bleeder valve under the bleeder valve.
- Since ink spatters when discharged if air is mixed into ink, use a deep container, and place it almost directly under the bleeder valve.
- Gradually increase a value of the "PUMP AIR REGULATOR" to start operating the pump. Then, adjust the operating speed within the range from 8 to 10 cycle per minute.
- Keep operating the pump in this condition until ink starts being discharged from the bleeder valve.
- When ink starts being discharged, stop the pump air and close the bleeder valve.

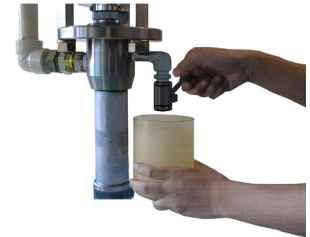

WARNING

- Do not touch any movable part of the pump nor let any part of your body come in contact with it while the pump is working.
- When ink is discharged from the bleeder valve, the compressed air may gush out as well. Be careful not to cause any ink to get in your eyes.
- Do not block the discharge port of the bleeder valve with your hand or finger.

ADJUSTING THE AIR PRESSURE THAT OPERATES THE PUMP

- Set the "PUMP AIR REGULATOR" to the regulated operation air pressure.
- Check to see how the pump plunger moves up and down. If the pump plunger moves down clearly faster than it moves up, it means that the suction capability of the pump cannot handle this condition. So, decrease the operation air pressure to adjust the pump so that it can operate normally.

NOTES

- If the plunger moves down faster than it moves up, the pump cannot discharge sufficient ink, and but the life of the pump is shortened if you continue operating the pump under this condition.
- The range of the normal operational air pressure changes depending on the viscosity and temperature of ink.

 CAUTION
<ul style="list-style-type: none">- The maximum available pressure of the pump is 100 psi. If you try to set pressure at a higher level, the pump may be damaged or it may cause injury or damage your surroundings. Never increase the pressure to 100 psi or higher.- Operate the pump with the lowest possible pressure (air pressure). This reduces meaningless movements and prevents each part from being worn out.

CLEANING THE INSIDE OF THE OIL CONTAINER AND REPLACING SOLVENT

The plunger sliding section and oil container of the pump are sealed with packing. When the plunger slides up and down repeatedly, solvent is accumulated at the rim of the plunger. Clean the plunger periodically.

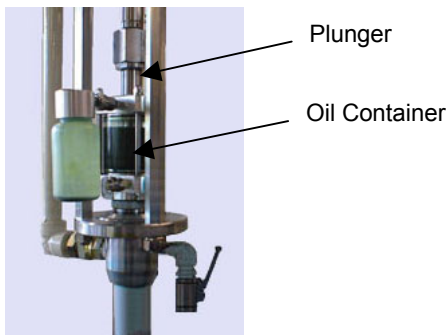

- Connect the hose mouthpiece of the dedicated oil evacuation gun to the lower coupler of the oil container, and suck oil by pulling the handle of the solvent removing device to discard it into the waste oil tank.

- Follow Section "Filling the oil container" to pour new oil from the upper coupler of the oil container into the container until the container is filled half-full with oil.
- When you move the the handle of the oil removing device connected to the lower coupler back and forth, oil poured into the container is stirred, and it cleans the inside of the container. When you replace the used oil with new oil and repeatedly stir the container several times, the container is cleaned.
- Finally, pour new oil into the container until approximately half of the container is filled with oil.

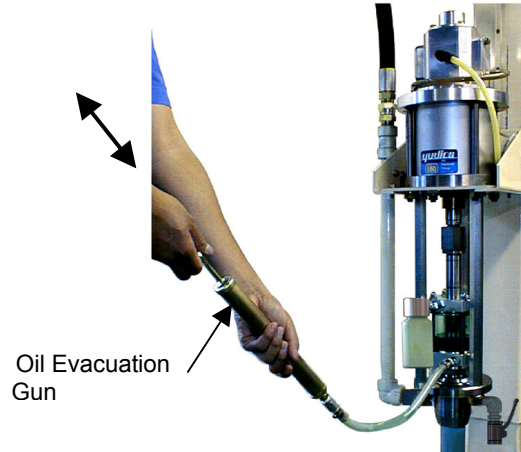

 CAUTION
<ul style="list-style-type: none">- To clean the plunger, stop the pump at its upper movable limit. If you try to clean the plunger while it is moving, your finger may be caught between the plunger and the oil container, and could result in an injury.

MAINTENANCE AND INSPECTION

- As part of the routine inspection, check to see how much oil has accumulated in the container due to leakage. Replace the oil with new oil according to the amount of the increased liquid.
- Further tighten each connection of the pump:
(1) During the regular maintenance operation
(2) If air leak or ink leak is detected during routine inspection.
- Since packing and other similar parts of the pump are worn out depending on how frequently they are used, check them regularly and replace them with new ones when necessary.

INK PUMP UNIT (TOTE TYPE)

PARTS LIST

Item No.	Description	Qty	Part No.			
			881042 IP140S3-TE	881051 IP140S12-TE	881030 IP200S25-TE	881031 IP250S20-TE
1	Ink Pump Assembly	1	853787	853862	853767	853768
2	Swivel Joint Assembly	1	804351	←	←	←
3	Bolt	4	611207	←	←	←
4	Washer	8	631015	←	←	←
5	Nut	4	627014	←	←	←
6	Spring Lock Washer	4	631422	←	←	←
7	O-ring (nitrile)	1	640067	←	←	←
8	Pump Holder	1	715140	←	←	←
9	Flange	2	715139	←	←	←
10	Gasket	1	772693	←	←	←
11	Plug (14 mm hex)	1	715062	←	←	←
12	Elbow Stand	1	714986	←	←	←

NOTE
TOTE KIT **853770**: Item No. 2 to 12

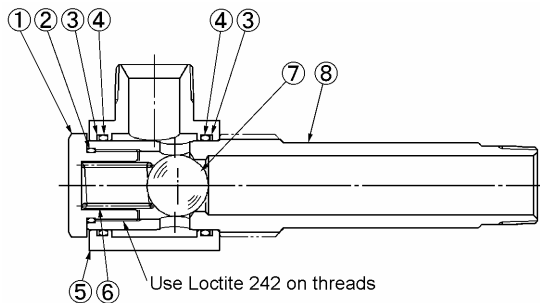

PARTS LIST

Item No.	Description	Qty.	Part No.
			Assembly 804351
1	Spring Guide (50 mm hex)	1	713793
2	O-ring (nitrile)	1	640132
3	Backup Ring	2	643705
4	O-ring (nitrile)	2	640045
5	Swivel Body	1	715054
6	Spring	1	713794
7	Ball	1	630488
8	Adapter (50 mm flats)	1	715055

804398 (Type 140)
804354 (Type 200)
AIR MOTOR
One exhaust port

804357 (Type 250)
AIR MOTOR
Two exhaust ports

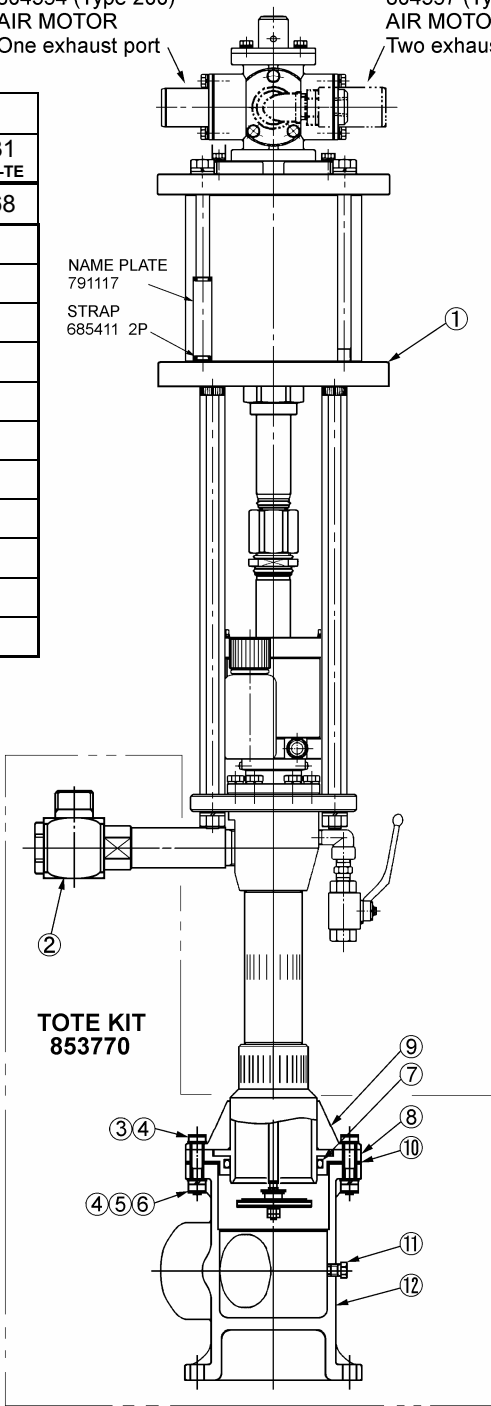

ELBOW STAND (TOTE TYPE)

EXPLODED VIEW

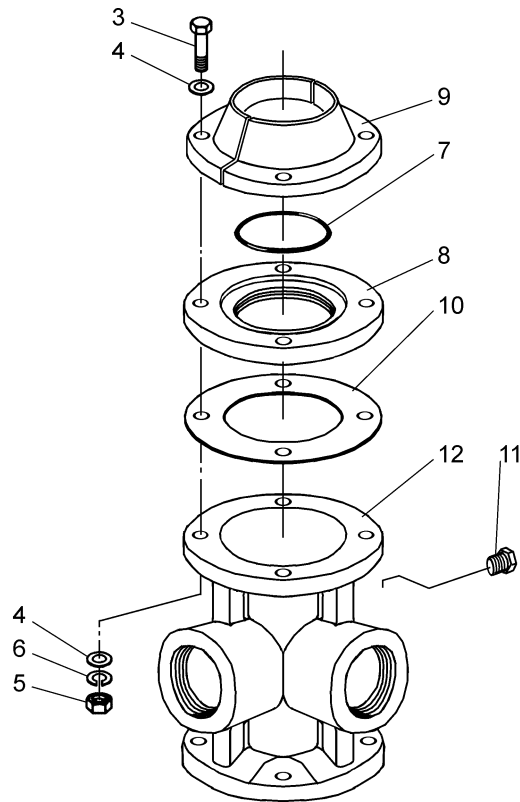

DISASSEMBLY PROCEDURE

1. Remove Bolt (Item 3) and Nut (Item 5) from Elbow Stand (Item 12).
2. Remove Flange (Item 9) from Pump Holder (Item 8).
3. Remove Pump Holder (Item 8) from Elbow Stand (Item 12).
 - 3.1 Remove O-Ring (Item 7) from Pump Holder (Item 8).
4. Remove Gasket (Item 10) from Elbow Stand (Item 12).
5. Remove Plug (Item 11) from Elbow Stand (Item 12).
6. To re-assemble TOTE KIT, reverse disassembly procedure.

AIR MOTOR ASSEMBLY (804398) For IP140S3-TE & IP140S12-TE (804354) For IP200S25-TE

PARTS LIST

Item No.	Description	Qty.	Parts No.	
			804398	804354
1	Elbow Fitting (22 mm hex)	1	684512	←
2	Silencer (36 mm hex)	1	713873	←
3	Street Elbow (22 mm hex)	1	634034	←
4	Bolt (13 mm hex)	4	611151	←
5	Spring Lock Washer	4	631420	←
6	Washer	4	631013	←
7	Switching Valve	1	804355	←
8	Pipe	1	715000	←
9	O-ring (nitrile)	1	640014	←
10	Bolt (7 mm hex)	2	611040	←
11	Spring Lock Washer	2	631415	←
12	Washer	2	631009	←
13	O-ring (nitrile)	1	685453	←
14	Upper Flange	1	715141	715001
15	O-ring (nitrile)	2	640152	640163
16	Air Cylinder	1	715142	714995
17	Tube	1	570144	←
18	Fitting (24 mm hex)	1	685450	←
19	Lower Flange	1	832695	832660
20	Plug	1	634362	←
21	Split Pin	1	632044	←
22	Packing	1	686104	←
23	Socket Bolt (5 mm hex key)	3	619101	←
24	Spring Lock Washer	3	631418	←
25	Piston Cap	1	713798	←
26	O-ring (nitrile)	1	640131	←
27	Trip Rod	1	714996	←
28	Spring	2	714295	←
29	Bolt	4	685515	685451
30	Spring Lock Washer	4	631422	631424
31	Washer	4	631015	631017
32	O-ring (nitrile)	1	640075	640088
33	Piston	1	832694	832661
34	O-ring (nitrile)	1	640041	←
35	O-ring (nitrile)	1	640136	←
36	Retainer (65 mm hex)	1	714997	←
37	Pin	1	685452	←
38	O-ring (nitrile)	1	640034	←
39	Connector (3 mm slit)	1	714998	←
40	Union (54 mm hex)	1	714999	←

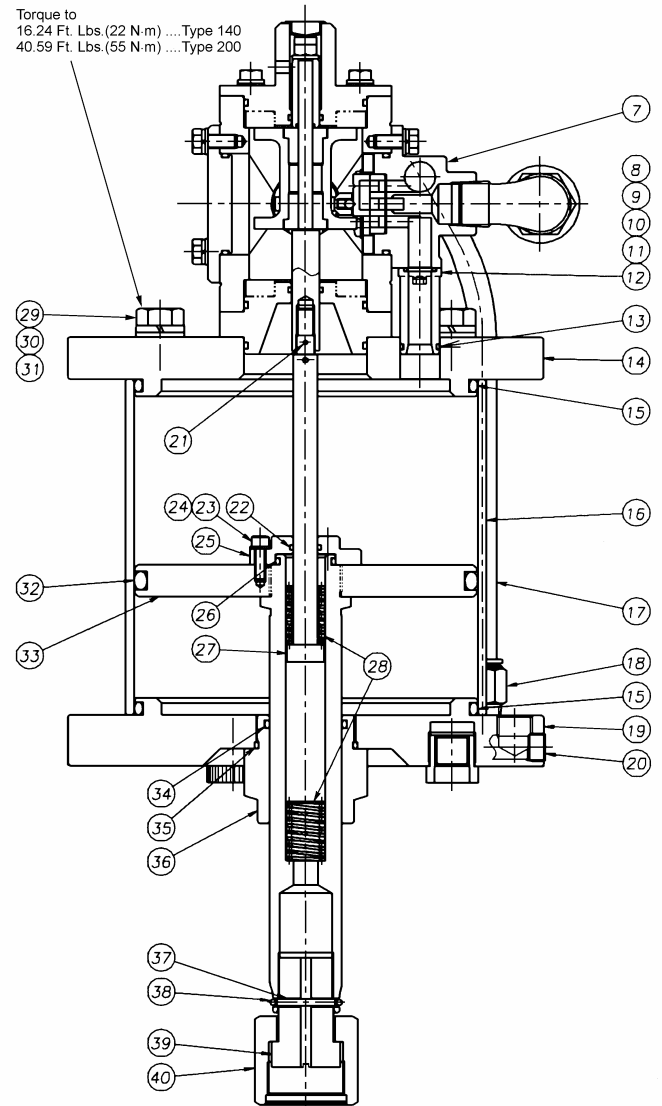
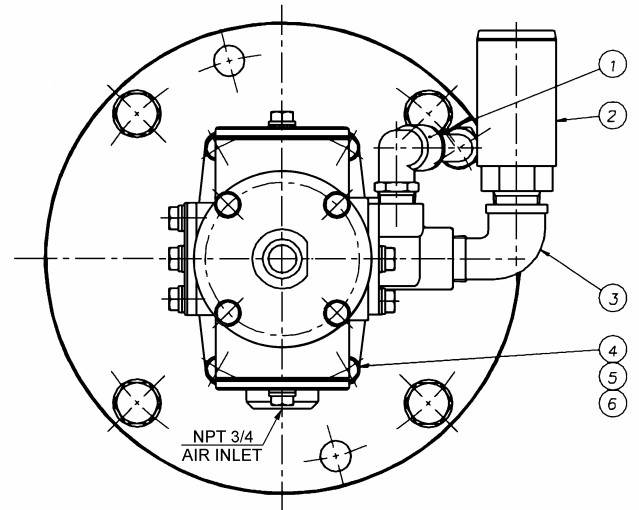

**AIR MOTOR ASSEMBLY
(804398)
For IP140S3-TE, IP140S12-TE**

**(804354)
For IP200S25-TE**

EXPLODED VIEW

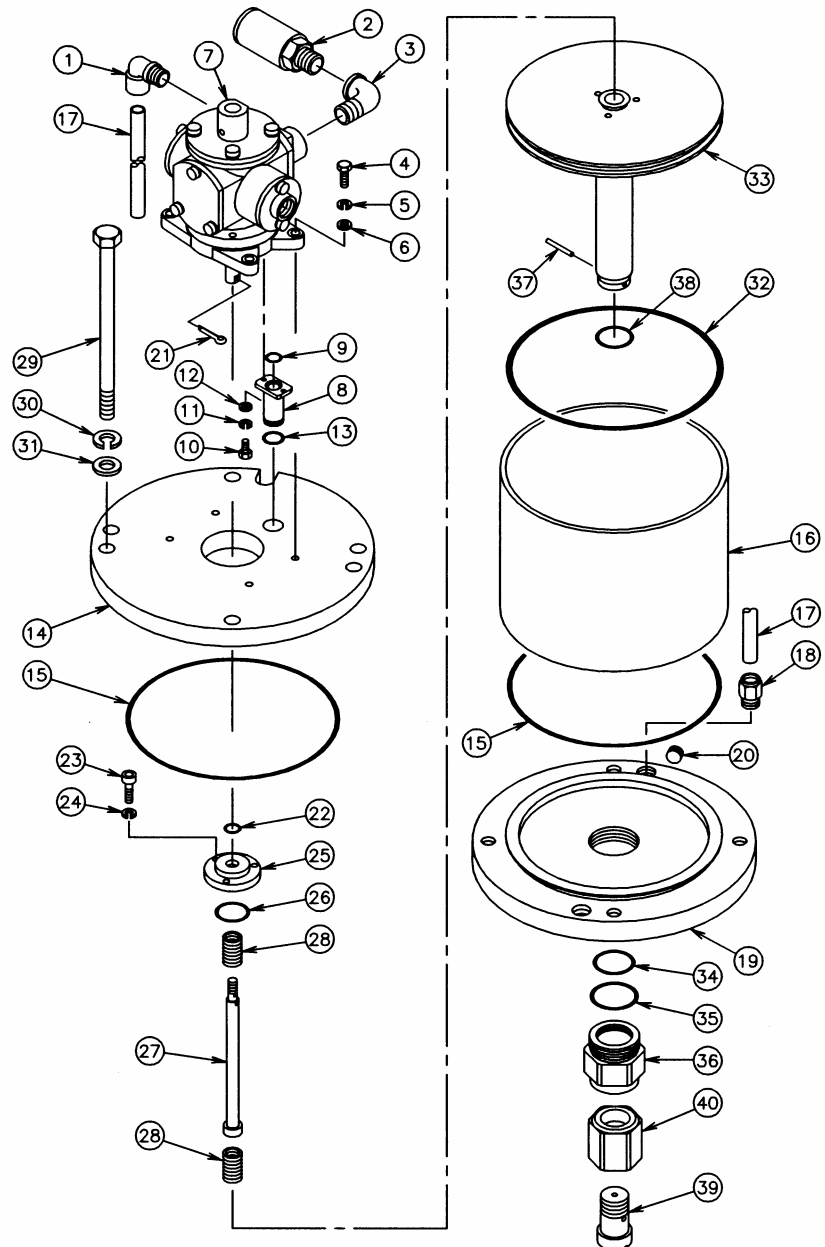

DISASSEMBLY PROCEDURE

1. Remove Silencer (Item 2) and Street Elbow (Item 3) from Switching Valve Assembly (Item 7).
2. Remove Tube (Item 17) from Fitting (Item 18).
 - 2-1. Remove Fitting (Item 18) from Lower Flange Assembly (Item 19).
 - 2-2. Remove Elbow Fitting (Item 1) from Switching Valve Assembly (Item 7).
3. Remove Bolt (Item 4) from Upper Flange (Item 14).
4. Remove Switching Valve Assembly (Item 7) from Upper Flange (Item 14).
5. Remove Bolt (Item 10) from Switching Valve Assembly (Item 7).
- 5-1. Remove O-Rings (Items 9 & 13) from Pipe (Item 8)
6. Remove Pin (Item 21) from Trip Rod (Item 27).
- 6-1. Remove Trip Rod (Item 27) from Switching Valve Assembly (Item 7).
7. Remove O-Ring (Item 38) from Piston Assembly (Item 33).
 - 7-1. Remove Pin (Item 37) from Piston Assembly (Item 33).
 - 7-2. Remove Connector (Item 39) from Piston Assembly (Item 33).
 - 7-3. Remove Union Nut (Item 40) from Connector (Item 39)
8. Remove Bolt (Item 29) from Upper Flange (Item 14).
 - 8-1. Remove Upper Flange (Item 14) from Air Cylinder (Item 16).
 - 8-2. Remove O-Ring (Item 15) from Upper Flange (Item 14).
9. Remove Air Cylinder (Item 16) from Lower Flange Assembly (Item 19).
10. Remove Piston Assembly (Item 33) from Lower Flange Assembly (Item 19).
11. Remove Socket Bolt (Item 23) from Piston Cap (Item 25).
 - 11-1. Remove Piston Cap (Item 25) from Piston Assembly (Item 33).
 - 11-2. Remove O-Ring (Item 22) from Piston Cap (Item 25).
12. Remove Trip Rod (Item 27) and Spring (Item 28) from Piston Assembly (Item 33).
13. Remove O-Rings (Item 26 & 32) from Piston Assembly (Item 33).
14. Remove Retainer (Item 36) from Lower Flange Assembly (Item 19).
 - 14-1. Remove O-Rings (Item 34 & 35) from Retainer (Item 36).
 - 14-2. Remove O-Ring (Item 15) from Lower Flange Assembly (Item 19).
15. To re-assemble Air Motor Assembly, reverse disassembly procedure. (Refer to illustration for torque specifications.)

AIR MOTOR ASSEMBLY (804357) For IP250S20-TE

PARTS LIST

Item No.	Description	Qty.	Part No.
1	Elbow Fitting (22 mm hex)	2	684512
2	Silencer (36 mm hex)	2	713873
3	Street Elbow	2	634034
4	Bolt (13 mm hex)	4	611151
5	Spring Lock Washer	4	631420
6	Washer	4	631013
7	Switching Valve	1	804358
8	Pipe	2	715000
9	O-ring (nitrile)	2	640014
10	Bolt (7 mm hex)	4	611040
11	Spring Lock Washer	4	631415
12	Washer	4	631009
13	O-ring (nitrile)	2	685453
14	Upper Flange	1	715036
15	O-ring (nitrile)	2	640169
16	Air Cylinder	1	715037
17	Tube	2	570144
18	Fitting (24 mm hex)	2	685450
19	Lower Flange	1	832666
20	Plug	2	634362
21	Split Pin	1	632044
22	Packing	1	686104
23	Socket Bolt (5 mm hex key)	3	619101
24	Spring Lock Washer	3	631418
25	Piston Cap	1	713798
26	O-ring (nitrile)	1	640131
27	Trip Rod	1	714996
28	Spring	2	714295
29	Bolt (24 mm hex)	4	685451
30	Spring Lock Washer	4	631424
31	Washer	4	631017
32	O-ring (nitrile)	1	640099
33	Piston	1	832667
34	O-ring (nitrile)	1	640041
35	O-ring (nitrile)	1	640136
36	Retainer (65 mm hex)	1	714997
37	Pin	1	685452
38	O-ring (nitrile)	1	640034
39	Connector (3 mm slit)	1	714998
40	Union (54 mm hex)	1	714999

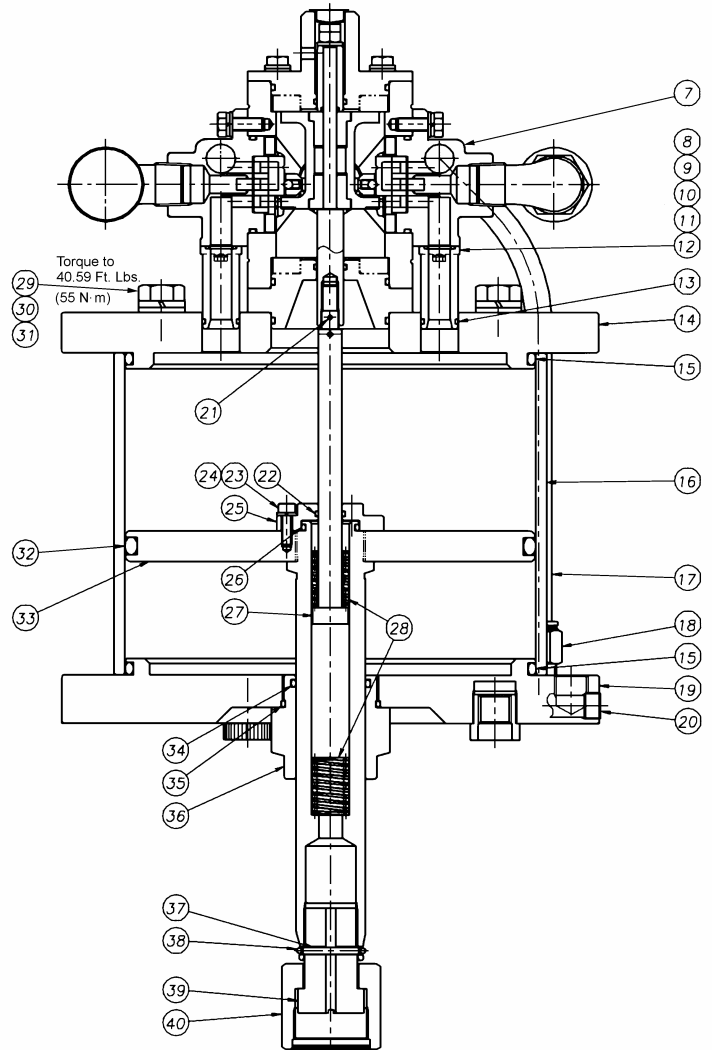
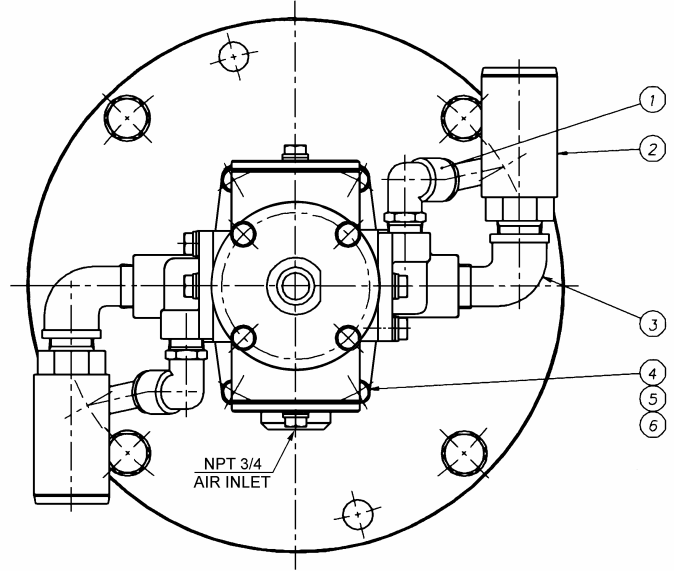

AIR MOTOR ASSEMBLY (804357) For IP250S20-TE

EXPLODED VIEW

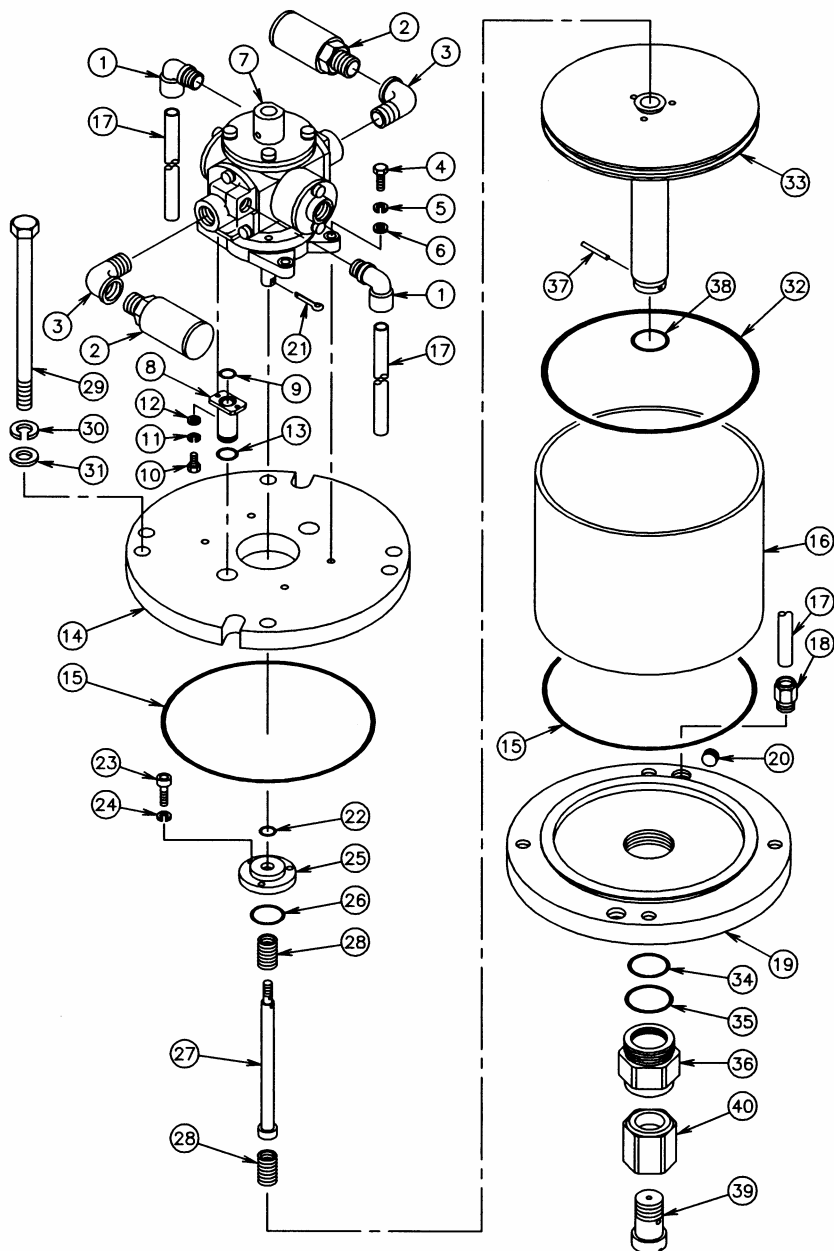

DISASSEMBLY PROCEDURE

1. Remove Silencer (Item 2) and Street Elbow (Item 3) from Switching Valve Assembly (Item 7).
2. Remove Tube (Item 17) from Fitting (Item 18).
 - 2-1. Remove Fitting (Item 18) from Lower Flange Assembly (Item 19).
 - 2-2. Remove Elbow Fitting (Item 1) from Switching Valve Assembly (Item 7).
3. Remove Bolt (Item 4) from Upper Flange (Item 14).
4. Remove Switching Valve Assembly (Item 7) from Upper Flange (Item 14).
5. Remove Bolt (Item 10) from Switching Valve Assembly (Item 7).
 - 5-1. Remove O-Rings (Items 9 & 13) from Pipe (Item 8)
6. Remove Pin (Item 21) from Trip Rod (Item 27).
 - 6-1. Remove Trip Rod (Item 27) from Switching Valve Assembly (Item 7).
7. Remove O-Ring (Item 38) from Piston Assembly (Item 33).
 - 7-1. Remove Pin (Item 37) from Piston Assembly (Item 33).
 - 7-2. Remove Connector (Item 39) from Piston Assembly (Item 33).
 - 7-3. Remove Union Nut (Item 40) from Connector (Item 39)
8. Remove Bolt (Item 29) from Upper Flange (Item 14).
 - 8-1. Remove Upper Flange (Item 14) from Air Cylinder (Item 16).
 - 8-2. Remove O-Ring (Item 15) from Upper Flange (Item 14).
9. Remove Air Cylinder (Item 16) from Lower Flange Assembly (Item 19).
10. Remove Piston Assembly (Item 33) from Lower Flange Assembly (Item 19).
11. Remove Socket Bolt (Item 23) from Piston Cap (Item 25).
 - 11-1. Remove Piston Cap (Item 25) from Piston Assembly (Item 33).
 - 11-2. Remove O-Ring (Item 22) from Piston Cap (Item 25).
12. Remove Trip Rod (Item 27) and Spring (Item 28) from Piston Assembly (Item 33).
13. Remove O-Rings (Item 26 & 32) from Piston Assembly (Item 33).
14. Remove Retainer (Item 36) from Lower Flange Assembly (Item 19).
 - 14-1. Remove O-Rings (Item 34 & 35) from Retainer (Item 36).
 - 14-2. Remove O-Ring (Item 15) from Lower Flange Assembly (Item 19).
15. To re-assemble Air Motor Assembly, reverse disassembly procedure. (Refer to illustration for torque specifications.)

SWITCHING VALVE ASSEMBLY

(804355) For IP140S3-TE & IP140S12-TE

For IP200S25-TE

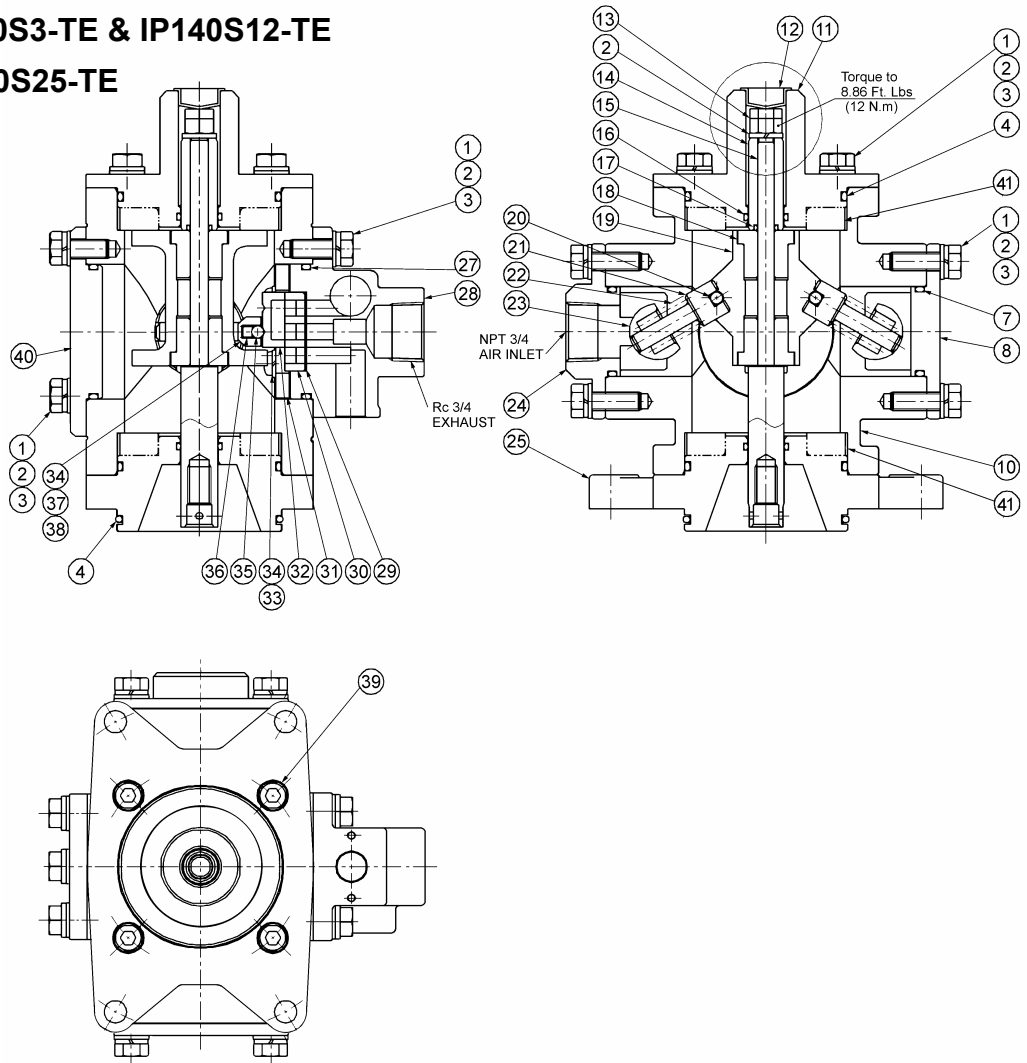

PARTS LIST

Item No.	Description	Qty.	Part No.	Item No.	Description	Qty.	Part No.
1	Bolt (13 mm hex)	14	611147	21	Trip Arm	2	714446
2	Spring Lock Washer	15	631420	22	Spring	2	684537
3	Washer	14	631013	23	Spring Guide	2	713620
4	O-ring (nitrile)	3	640138	24	Retainer	1	715114
5	---	---	---	25	Base Cap	1	715117
6	---	---	---	26	---	---	---
7	O-ring (nitrile)	2	640132	27	O-ring (nitrile)	2	640136
8	Retainer	1	714818	28	Valve Body	1	715115
9	---	---	---	29	Gasket	1	772331
10	Valve Cylinder	1	715113	30	Valve Seat	1	705688
11	Cap	1	714820	31	Valve Guide	1	705687
12	Cap	1	684249	32	Block	1	705693
13	Lock Nut (13 mm hex)	1	685454	33	Screw	4	685942
14	Bushing	1	713515	34	Spring Lock Washer	6	631418
15	Valve Rod (15 mm flats)	1	715010	35	Ball (7/32")	1	630313
16	O-ring (nitrile)	2	640015	36	Spring	1	706612
17	O-ring (nitrile)	1	640005	37	Block Holder	1	705700
18	Bushing	2	713517	38	Screw	2	602297
19	Valve Switcher	1	713518	39	Socket Bolt (6 mm hex key)	4	619147
20	Pin	2	700231	40	Cap	1	715116
				41	Cushion	2	770549

SWITCHING VALVE ASSEMBLY (804355) For IP140S3-TE & IP140S12-TE, IP200S25-TE

EXPLODED VIEW

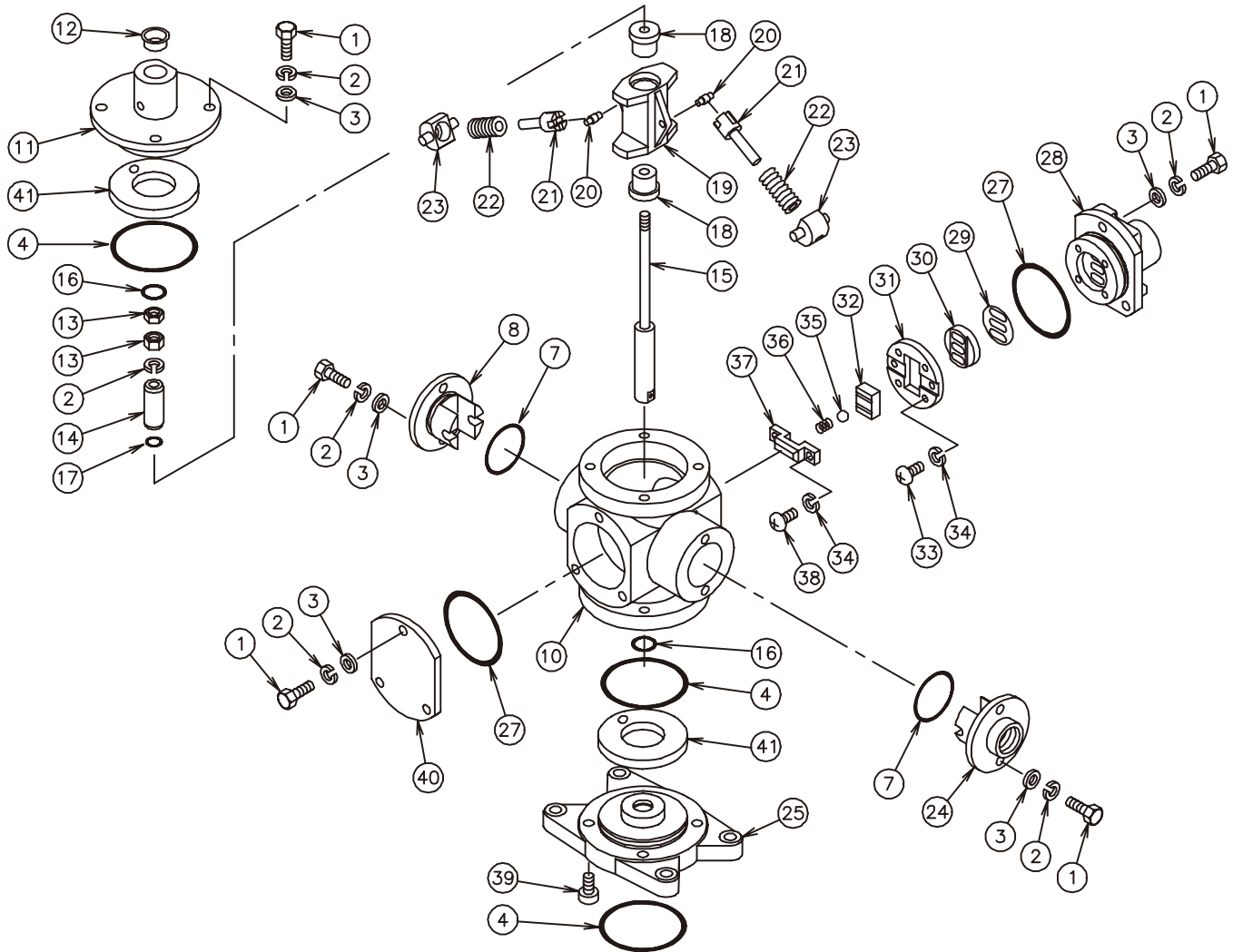

DISASSEMBLY PROCEDURE

1. Remove Bolt (Item 1) from Retainer (Item 8 and 24).
 - 1-1. Remove Retainer (Item 8 and 24) from Valve Cylinder (Item 10).
 - a. Remove O-Ring (Item 7) from Retainer (Item 8 and 24).
 - 1-2. Remove Spring Guide (Item 23), Spring (Item 22) and Trip Arm (Item 21) from Valve Cylinder (Item 10).
 - 1-3. Remove Pin (Item 20) from Valve Switcher (Item 19).
2. Remove Bolt (Item 1) from Valve Body (Item 28).
 - 2-1. Remove O-Ring (Item 27) from Valve Body (Item 28).
 - 2-2. Remove Screw (Item 38) from Block Holder (Item 37).
 - 2-3. Remove Block Holder (Item 37), Spring (Item 36) and Ball (Item 35) from Block (Item 32).
 - 2-4. Remove Block (Item 32) from Block Guide (Item 31).
 - 2-4. Remove Screw (Item 33) from Block Guide (Item 31).
 - 2-5. Remove Valve Guide (Item 31) from Valve Body (Item 28).
 - 2-6. Remove Valve Seat (Item 30) and Gasket (Item 29) from Valve Body (Item 28).
3. Remove Cap (Item 12) from Cap (Item 11).
 - 3-1. Remove Bolt (Item 1) from Cap (Item 11).
 - 3-2. Remove Cap (Item 11) from Valve Cylinder (Item 10).
 - 3-3. Remove O-Rings (Items 4 & 16) and Cushion (item 41) from Cap (Item 11).
4. Remove Valve Rod Assembly (Item 15) from Valve Cylinder (Item 10).
 - 4-1. Remove Lock Nut (Item 13) from Valve Rod Assembly (Item 15).
 - 4-2. Remove Spring Washer (Item 2) and Bushing (Item 14) from Valve Rod Assembly (Item 15).
 - 4-3. Remove O-Ring (Item 17) from Bushing (Item 14).
5. Remove Valve Rod Assembly (Item 15), Valve Switcher (Item 19) and Bushing (Item 18) from Valve Cylinder (Item 10).
 - 5-1. Remove Valve Rod Assembly (Item 15) from Valve Switcher (Item 19).
 - 5-2. Remove Bushing (Item 18) from Valve Switcher (Item 19).
6. Remove Bolt (Item 39) from Base Cap (Item 25).
 - 6-1. Remove O-Ring (Item 4) and Cushion (item 41) from both sides of the Base Cap (Item 25).
 - 6-2. Remove O-Ring (Item 16) from Base Cap (Item 25).
7. To re-assemble Switching Valve Assembly, reverse disassembly procedure. (Refer to illustration for torque specifications.)

SWITCHING VALVE ASSEMBLY

(804358) For IP250S20-TE

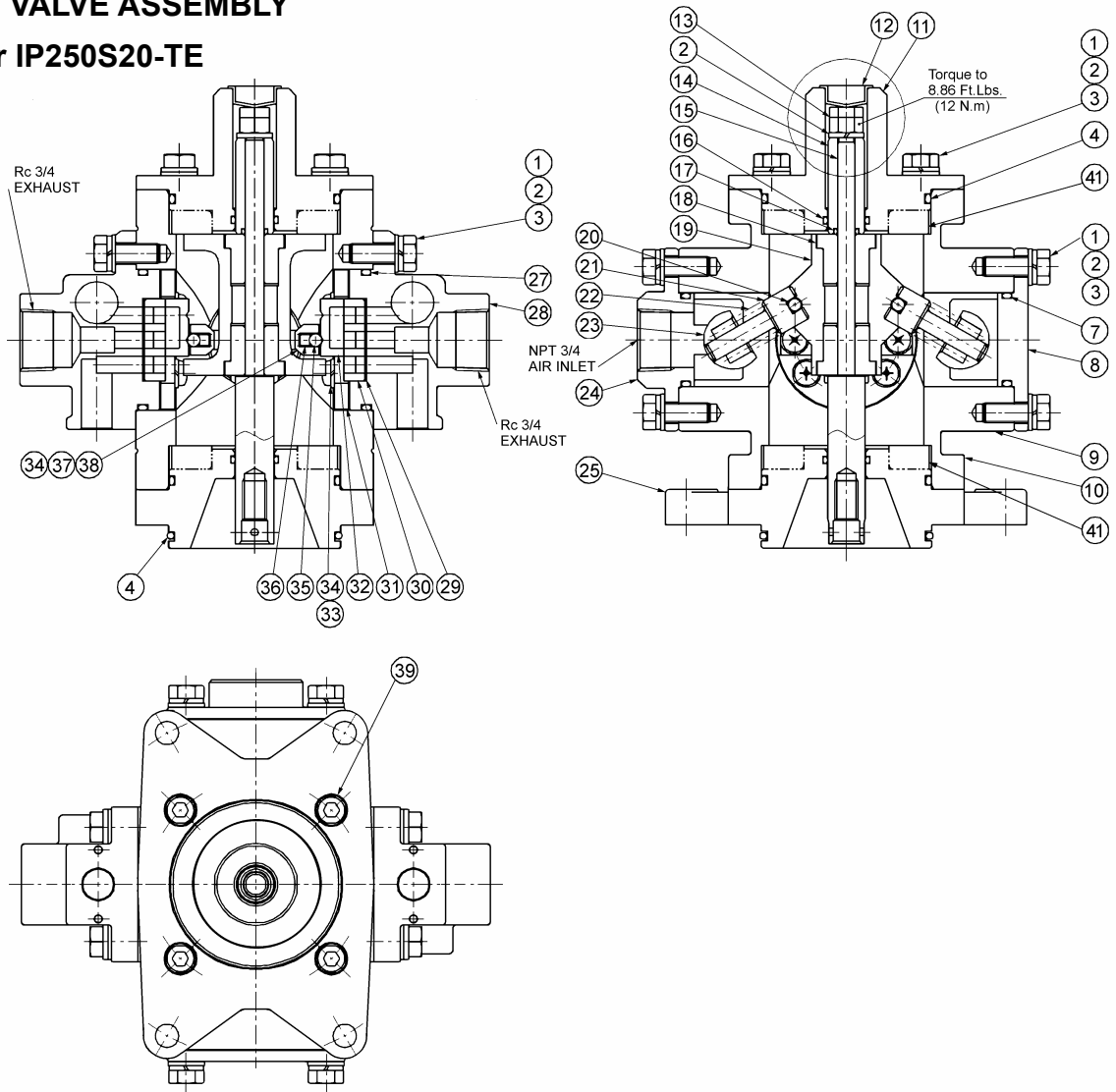

PARTS LIST

Item No.	Description	Qty.	Part No.	Item No.	Description	Qty.	Part No.
1	Bolt (13 mm hex)	14	611147	21	Trip Arm	2	714446
2	Spring Lock Washer	15	631420	22	Spring	2	684537
3	Washer	14	631013	23	Spring Guide	2	713620
4	O-ring (nitrile)	3	640138	24	Retainer	1	715114
5	---	---	---	25	Base Cap	1	715117
6	---	---	---	26	---	---	---
7	O-ring (nitrile)	2	640132	27	O-ring (nitrile)	2	640136
8	Retainer	1	714818	28	Valve Body	2	715115
9	---	---	---	29	Gasket	2	772331
10	Valve Cylinder	1	715113	30	Valve Seat	2	705688
11	Cap	1	714820	31	Valve Guide	2	705687
12	Cap	1	684249	32	Block	2	705693
13	Lock Nut (13 mm hex)	1	685454	33	Screw	8	685942
14	Bushing	1	713515	34	Spring Lock Washer	12	631418
15	Valve Rod (15 mm flats)	1	715010	35	Ball (7/32")	2	630313
16	O-ring (nitrile)	2	640015	36	Spring	2	706612
17	O-ring (nitrile)	1	640005	37	Block Holder	2	705700
18	Bushing	2	713517	38	Screw	4	602297
19	Valve Switcher	1	713518	39	Socket Bolt (6 mm hex key)	4	619147
20	Pin	2	700231	41	Cushion	2	770549

SWITCHING VALVE ASSEMBLY (804358) For IP250S20-TE

EXPLODED VIEW

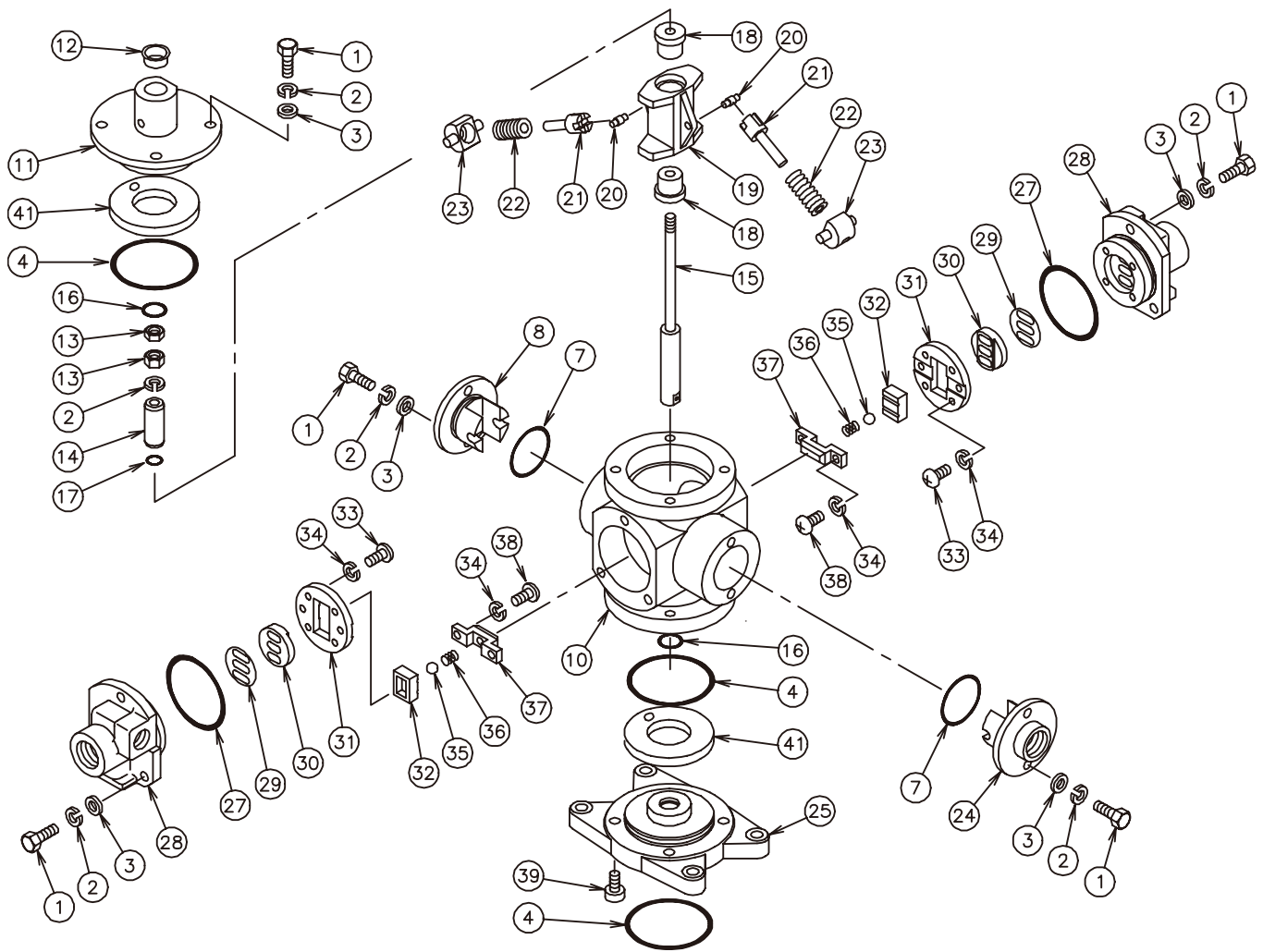

DISASSEMBLY PROCEDURE

1. Remove Bolt (Item 1) from Retainer (Item 8 and 24).
 - 1-1. Remove Retainer (Item 8 and 24) from Valve Cylinder (Item 10).
 - a. Remove O-Ring (Item 7) from Retainer (Item 8 and 24).
 - 1-2. Remove Spring Guide (Item 23), Spring (Item 22) and Trip Arm (Item 21) from Valve Cylinder (Item 10).
 - 1-3. Remove Pin (Item 20) from Valve Switcher (Item 19).
2. Remove Bolt (Item 1) from Valve Body (Item 28).
 - 2-1. Remove O-Ring (Item 27) from Valve Body (Item 28).
 - 2-2. Remove Screw (Item 38) from Block Holder (Item 37).
 - 2-3. Remove Block Holder (Item 37), Spring (Item 36) and Ball (Item 35) from Block (Item 32).
 - 2-4. Remove Block (Item 32) from Block Guide (Item 31).
 - 2-4. Remove Screw (Item 33) from Block Guide (Item 31).
 - 2-5. Remove Valve Guide (Item 31) from Valve Body (Item 28).
 - 2-6. Remove Valve Seat (Item 30) and Gasket (Item 29) from Valve Body (Item 28).
3. Remove Cap (Item 12) from Cap (Item 11).
 - 3-1. Remove Bolt (Item 1) from Cap (Item 11).
 - 3-2. Remove Cap (Item 11) from Valve Cylinder (Item 10).
 - 3-3. Remove O-Rings (Items 4 & 16) and Cushion (item 41) from Cap (Item 11).
4. Remove Valve Rod Assembly (Item 15) from Valve Cylinder (Item 10).
 - 4-1. Remove Lock Nut (Item 13) from Valve Rod Assembly (Item 15).
 - 4-2. Remove Spring Washer (Item 2) and Bushing (Item 14) from Valve Rod Assembly (Item 15).
 - 4-3. Remove O-Ring (Item 17) from Bushing (Item 14).
5. Remove Valve Rod Assembly (Item 15), Valve Switcher (Item 19) and Bushing (Item 18) from Valve Cylinder (Item 10).
 - 5-1. Remove Valve Rod Assembly (Item 15) from Valve Switcher (Item 19).
 - 5-2. Remove Bushing (Item 18) from Valve Switcher (Item 19)
6. Remove Bolt (Item 39) from Base Cap (Item 25).
 - 6-1. Remove O-Ring (Item 4) from both sides of the Base Cap (Item 25).
 - 6-2. Remove O-Ring (Item 16) and Cushion (item 41) from Base Cap (Item 25).
7. To re-assemble Switching Valve Assembly, reverse disassembly procedure. (Refer to illustration for torque specifications.)

SUCTION PUMP ASSEMBLY (804399) For IP140S3-TE

PARTS LIST

Item No.	Description	Qty.	Part No.
1	O-ring	1	640040
2			
3			
4			
5	Plunger (46 mm flats)	1	715145
6	Bolt (13 mm hex)	2	685267
7	Spring Lock Washer	3	631420
8	Washer	2	631013
9	Packing	1	684711
10	Cap	1	715146
11	O-ring (nitrile)	4	640149
12	Oil Cap	1	772143
13	Socket	1	715147
14	O-ring (nitrile)	1	640146
15	Screw	2	602284
16	Bolt (16 mm hex)	6	685457
17	Spring Lock Washer	6	631421
18	Gland Retainer	1	715148
19	Backup Ring	1	685119
20	O-ring (nitrile)	1	640147
21	Coupler	2	680742
22	Nipple (14 mm hex)	1	680743
23	Adapter	1	715993
24	Packing	1	772330
25	Bottle	1	686106
26	Packing Gland	1	713839
27	Backup Ring	1	684712
28	Packing	1	684713
29	Street Elbow	1	681198
30	Nipple	1	685367
31	Valve	1	685354
32	Body	1	715149
33	Suction Tube	1	715150
34	Valve Stopper	1	715151
35	Spacer	1	715152
36	Valve Seat	1	715153
37	O-ring (nitrile)	1	640144
38	Foot Valve Housing	1	715154
39	O-ring (nitrile)	2	640130
40	Pin	1	685462
41	O-ring (nitrile)	1	640042
42	Piston Body	1	715155
43	O-ring (nitrile)	1	640067
44	Backup Ring	1	643727
45	Wear Ring	1	772185
46	Piston Valve	1	715156
47	O-ring (nitrile)	1	640009
49	Pin	1	632547
50	Shovel Rod	1	715027
51	Foot Valve	1	715157
52	Backup Ring	2	643669
53	Valve Guide	1	713551
54	Valve Plate	1	713552
55	Shovel	1	713553
56	Lock Nut (13 mm hex)	1	681886
57	Backup Ring	2	685362
58	Packing	1	685546
59	Throat Bearing	1	772184

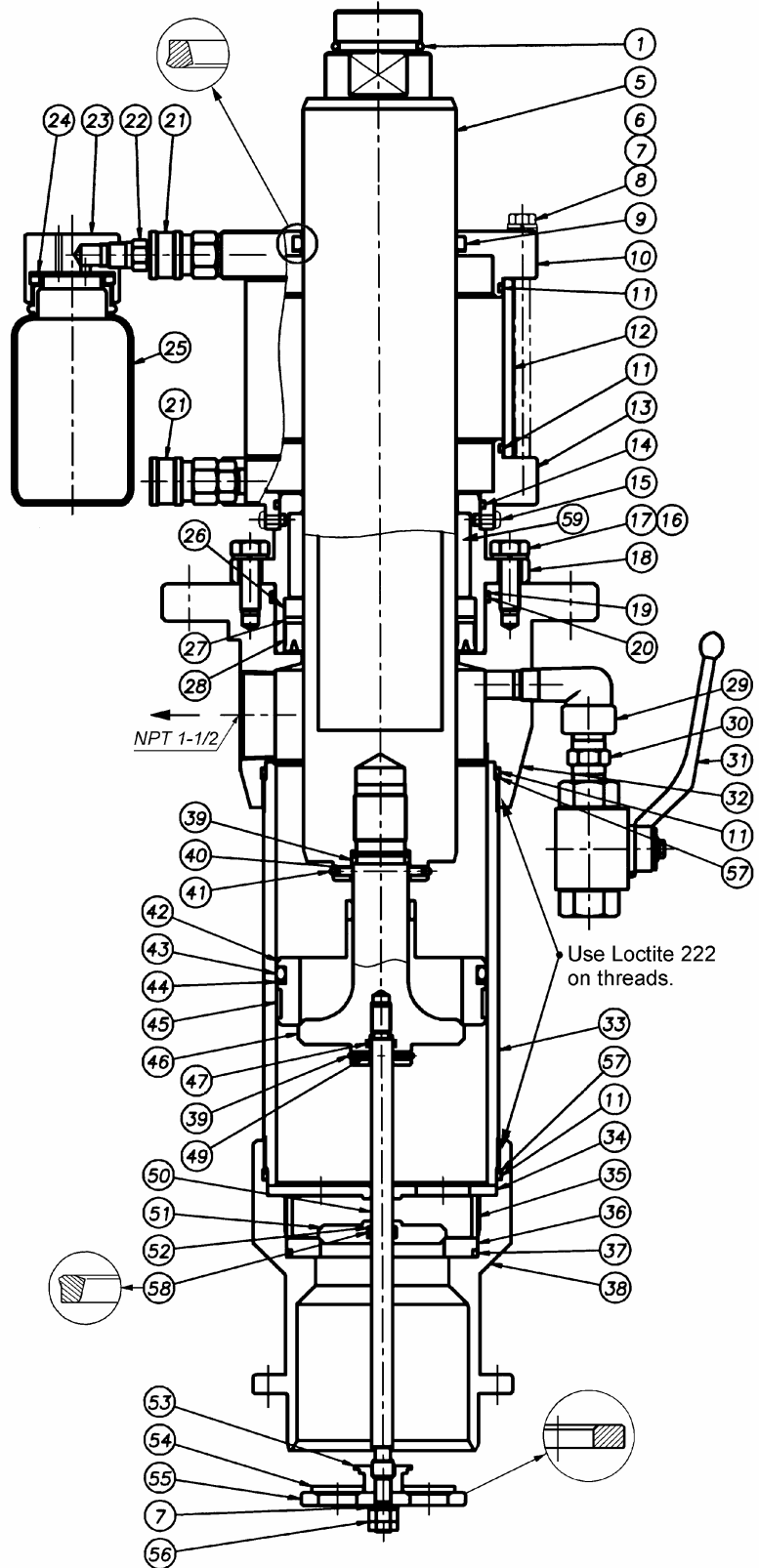

SUCTION PUMP ASSEMBLY (804399) For IP140S3-TE

EXPLODED VIEW

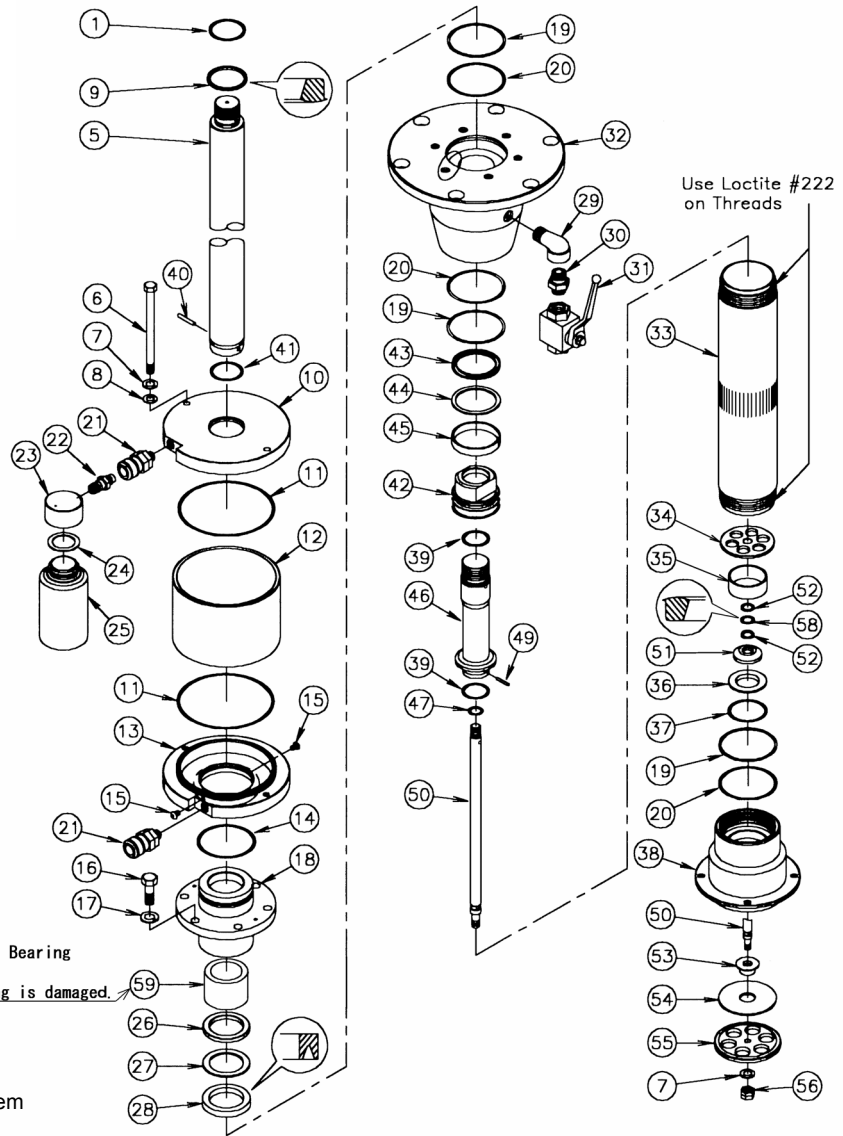

Do not remove the Throat Bearing from the Gland Retainer unless the Throat Bearing is damaged.

DISASSEMBLY PROCEDURE

1. Remove Coupler (Item 21) from Nipple (Item 22).
 - 1-1. Remove Bottle (Item 25) and Adapter (Item 23) from Nipple (Item 22).
 - 1-2. Remove Packing (Item 24) from Adapter (Item 23).
2. Remove Set Screw (Item 15) from Socket (Item 13).
 - 2-1. Remove Bolt (Item 6) from Cap (Item 10).
 - 2-2. Remove Cap (Item 10) from Oil Cup (Item 12).
 - 2-3. Remove Packing (Item 9) and O-ring (Item 11) from Cap (Item 10).
 - 2-3. Remove O-rings (Item 11 & 14) from Socket (Item 13).
3. Remove Lock-Nut (Item 56) and Spring Washer (Item 7) from Shovel Rod (Item 50).
 - 3-1. Remove Shovel (Item 55), Valve Plate (Item 54) and Valve Guide (Item 53) from Shovel Rod (Item 50).
4. Remove Foot Valve Housing (Item 38) from Suction Tube (Item 33).
 - 4-1. Remove Back-up Ring (Item 57) and O-Ring (Item 11) from Foot Valve Housing (Item 38).
 - 4-2. Remove Valve Stopper (Item 34) and Spacer (Item 35) from Foot Valve Housing (Item 38).
 - 4-3. Remove Foot Valve (Item 51) from Foot Valve Housing (Item 38).
 - a. Remove Back-up Ring (Item 52) and Packing (Item 58) from Foot Valve (Item 51)
- 4-4. Remove Valve Seat (Item 36) and O-Ring (Item 37) from Foot Valve Housing (Item 38).
5. Remove Suction Tube (Item 33) from Body (Item 32).
6. Remove O-Ring (Item 39) from Piston Valve (Item 46).
7. Remove Pin (Item 79) from Piston Valve (Item 46).
8. Remove Shovel Rod (Item 50) from Piston Valve (Item 46).
9. Remove Piston Valve (Item 46) and Plunger (Item 5) from Body (Item 32).
 - 9-1. Remove O-Ring (Item 41) from Plunger (Item 5).
 - 9-2. Remove Pin (Item 40) from Plunger (Item 5).
 - 9-3. Remove Piston Valve (Item 46) from Plunger (Item 5).
 - 9-4. Remove O-Ring (Item 39) from Piston Valve (Item 46).
10. Remove Piston Body (Item 42) from Piston Valve (Item 46).
 - 10-1. Remove O-Ring (Item 43), Back-up Ring (Item 44) and Wear Ring (Item 45) from Piston Body (Item 42).
11. Remove Bolt (Item 16) from Gland Retainer (Item 18).
12. Remove Gland Retainer (Item 18) from Body (Item 32).
 - 12-1. Remove U-Packing (Item 28), Back-up Ring (Item 27) and Packing Gland (Item 26) from Gland Retainer (Item 18).
13. Remove Back-up Ring (Item 19) and O-Ring (Item 20) from both sides of the Body (Item 32).
14. To re-assemble lower pump, reverse disassembly procedure.

**SUCTION PUMP ASSEMBLY (804356) For IP140S12-TE & IP200S25-TE,
(804359) For IP250S20-TE**

PARTS LIST

Item	Description	Qty.	Part No.	
			804356	804359
1	O-ring	1	640040	←
2	Bushing(46 mm flats)	1	715029	←
3	O-ring (nitrile)	1	640037	←
4	Pin	1	685471	←
5	Plunger(46 mm flats)	1	715015	715040
6	Bolt (13 mm hex)	2	685267	←
7	Spring Lock Washer	3	631420	←
8	Washer	2	631013	←
9	Packing	1	685456	685460
10	Cap	1	715016	715041
11	O-ring (nitrile)	2	640149	←
12	Oil Cap	1	772143	←
13	Socket	1	715017	715042
14	O-ring (nitrile)	1	640137	640141
15	Screw	2	602284	←
16	Bolt (16 mm hex)	6	685457	←
17	Spring Lock Washer	6	631421	←
18	Gland Retainer	1	715030	715053
19	Backup Ring	3	685359	685361
20	O-ring (nitrile)	3	640138	640143
21	Coupler	2	680742	←
22	Nipple (14 mm hex)	1	680743	←
23	Adapter	1	715993	←
24	Packing	1	772330	←
25	Bottle	1	686106	←
26	Packing Gland	1	715019	715044
27	Backup Ring	1	772694	772698
28	Packing	1	685458	685461
29	Street Elbow	1	681198	←
30	Nipple	1	685367	←
31	Valve	1	685354	←
32	Body	1	715018	715043
33	Suction Tube	1	715020	715045
34	Valve Stopper	1	715022	715047
35	Spacer	1	715023	715048
36	Valve Seat	1	715024	715049
37	O-ring (nitrile)	1	640136	640140
38	Foot Valve Housing	1	715137	715138
39	O-ring (nitrile)	1	640017	←
40	Pin	2	640130	←
41	O-ring (nitrile)	1	685455	685462
42	Piston Body	1	640025	640042
43	Packing	1	715025	715050
44	Packing	2	685459	685463
45	Backup Ring	2	772695	685464
46	Wear Ring	1	772696	772699
47	Piston Valve	1	715026	715051
48	O-ring (nitrile)	1	640009	←
49	O-ring (nitrile)	1	640015	←
50	Pin	1	632544	632547
51	Shovel Rod	1	715027	←
52	Foot Valve	1	715028	715052
53	Backup Ring	2	643669	←
54	Valve Guide	1	713551	←
55	Valve Plate	1	713552	←
56	Shovel	1	713553	←
57	Lock Nut(13 mm hex)	1	681886	←
58	Packing	1	685546	←
59	Throat Bearing	1	772697	772700

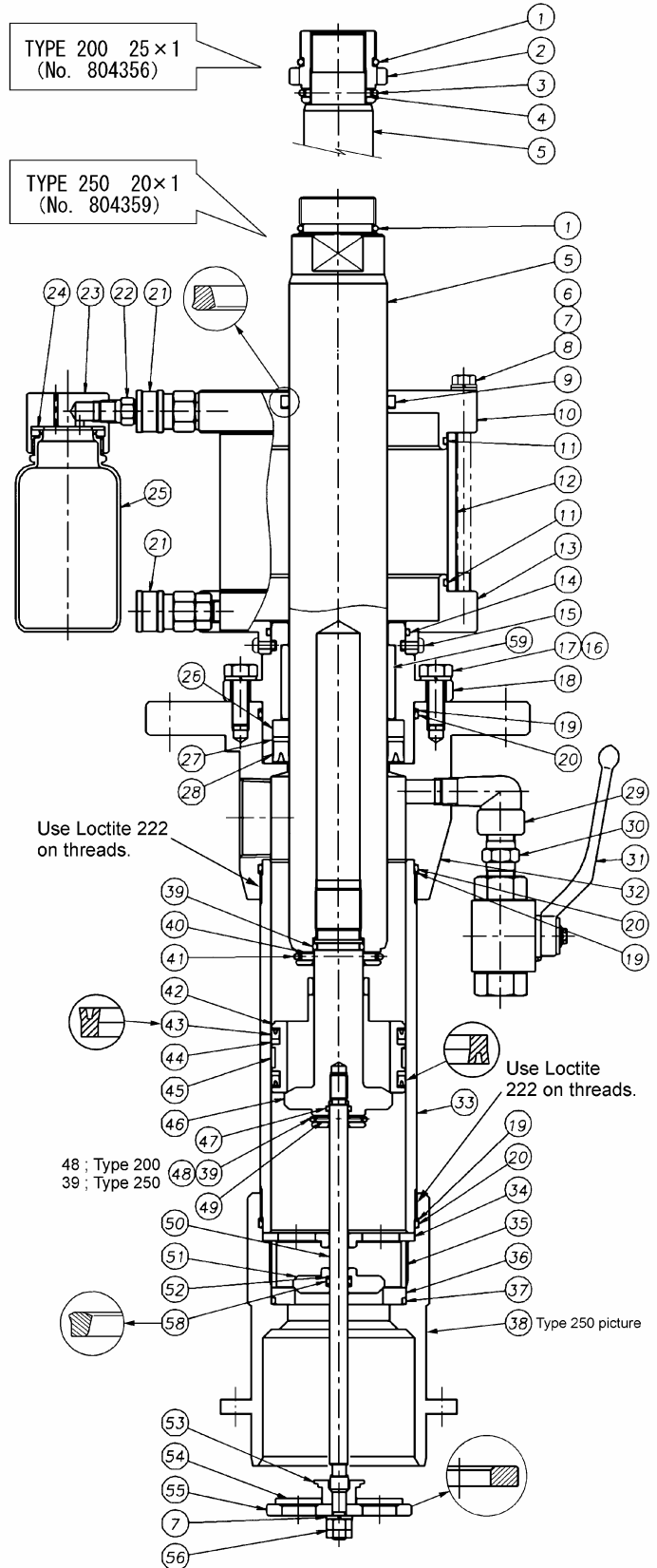

SUCTION PUMP ASSEMBLY
(804356) For IP140S12-TE
For IP200S25-TE
(804359) For IP250S20-TE

EXPLODED VIEW

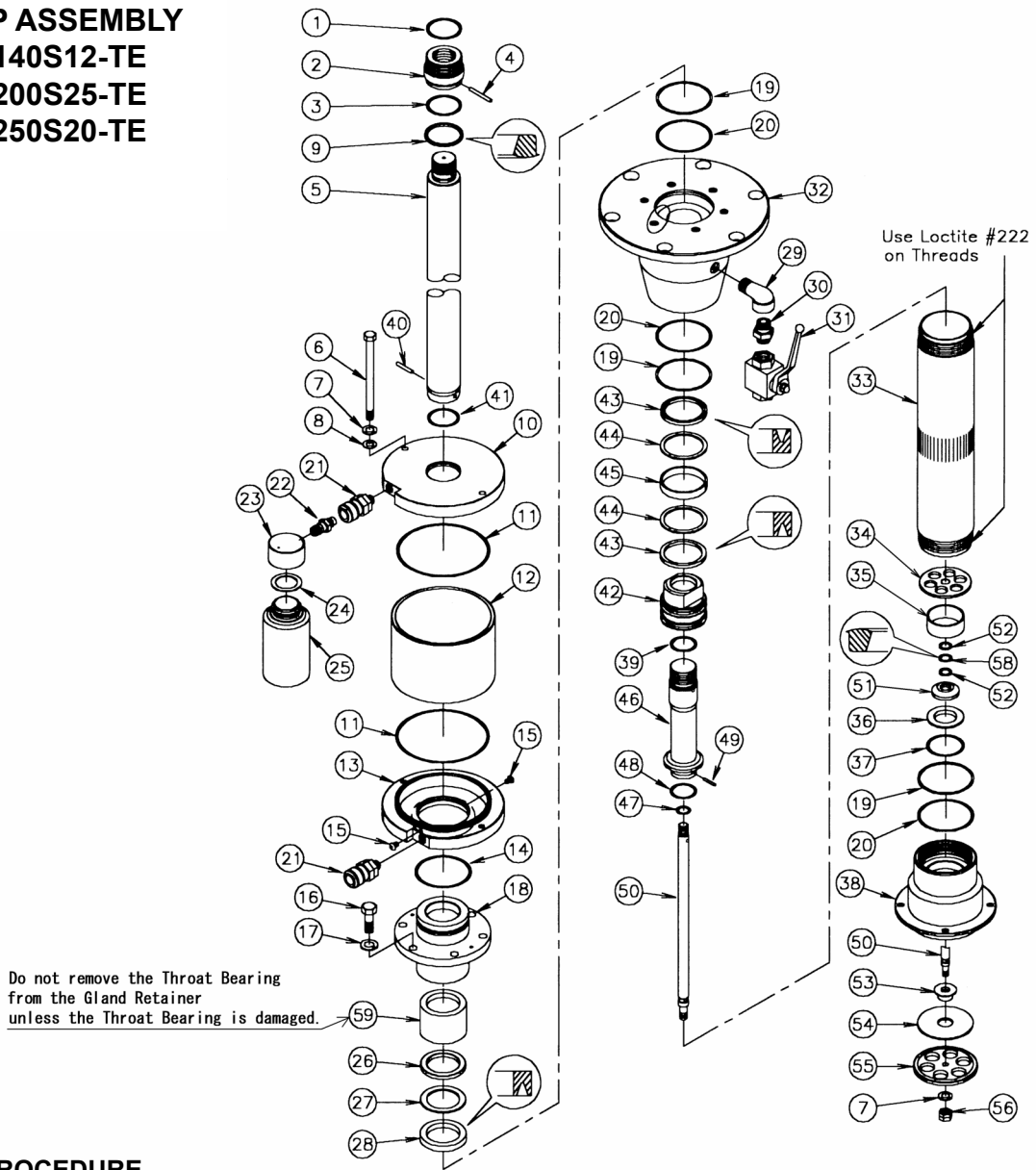

DISASSEMBLY PROCEDURE

1. Remove Coupler (Item 21) from Nipple (Item 22).
 - 1-1. Remove Bottle (Item 25) and Adapter (Item 23) from Nipple (Item 22).
 - 1-2. Remove Packing (Item 24) from Adapter (Item 23).
2. Remove Set Screw (Item 15) from Socket (Item 13).
 - 2-1. Remove Bolt (Item 6) from Cap (Item 10).
 - 2-2. Remove Cap (Item 10) from Oil Cup (Item 12).
 - 2-3. Remove Packing (Item 9) and O-ring (Item 11) from Cap (Item 10).
 - 2-3. Remove O-rings (Item 11 & 14) from Socket (Item 13).
3. Remove Lock-Nut (Item 56) and Spring Washer (Item 7) from Shovel Rod (Item 50).
 - 3-1. Remove Shovel (Item 55), Valve Plate (Item 54) and Valve Guide (Item 53) from Shovel Rod (Item 50).
4. Remove Foot Valve Housing (Item 38) from Suction Tube (Item 33).
 - 4-1. Remove Back-up Ring (Item 19) and O-Ring (Item 20) from Foot Valve Housing (Item 38).
 - 4-2. Remove Valve Stopper (Item 34) and Spacer (Item 35) from Foot Valve Housing (Item 38).
 - 4-3. Remove Foot Valve (Item 51) from Foot Valve Housing (Item 38).
 - a. Remove Back-up Ring (Item 52) and Packing (Item 58) from Foot Valve (Item 51)
- 4-4. Remove Valve Seat (Item 36) and O-Ring (Item 37) from Foot Valve Housing (Item 38).
5. Remove Suction Tube (Item 33) from Body (Item 32).
6. Remove O-Ring (Item 39) from Piston Valve (Item 46).
7. Remove Pin (Item 49) from Piston Valve (Item 46).
8. Remove Shovel Rod (Item 50) from Piston Valve (Item 46).
9. Remove Piston Valve (Item 46) and Plunger (Item 5) from Body (Item 32).
 - 9-1. Remove O-Ring (Item 41) from Plunger (Item 5).
 - 9-2. Remove Pin (Item 40) from Plunger (Item 5).
 - 9-3. Remove Piston Valve (Item 46) from Plunger (Item 5).
 - 9-4. Remove O-Ring (Item 39) from Piston Valve (Item 46).
10. Remove Piston Body (Item 42) from Piston Valve (Item 46).
 - 10-1. Remove U-Packing (Item 43), Back-up Ring (Item 44) and Wear Ring (Item 45) from Piston Body (Item 42).
11. Remove Bolt (Item 16) from Gland Retainer (Item 18).
12. Remove Gland Retainer (Item 18) from Body (Item 32).
 - 12-1. Remove U-Packing (Item 28), Back-up Ring (Item 27) and Packing Gland (Item 26) from Gland Retainer (Item 18).
13. Remove Back-up Ring (Item 19) and O-Ring (Item 20) from both sides of the Body (Item 32).
14. To re-assemble lower pump, reverse disassembly procedure.

TROUBLESHOOTING

State	Cause	Action to be taken
Pump does not run	Air is not supplied.	Start the compressor, and open the air valve and air regulator.
	The supply pressure is low.	Set the air pressure to 30 psi or more.
	The discharge flow valve is not open.	Open the ink delivery valve.
	Icing inside exhaust port.	Install air line coalescing filter to remove moisture.
Pump does not prime ink during stat up.	The supply air pressure is too high.	Until pump discharge ink from bleeder valve, run pump 8-10 cycle per minute.
Pump does not deliver ink	If the plunger operates faster during the moving-up process, the seat of the piston valve malfunctions (the seat section is worn out or a foreign substance is mixed into the valve), or the packing or similar part is damaged.	Replace the malfunctioning part with a new one, or remove the foreign substance.
	If the plunger operates faster during the moving-down process, the seat of the foot valve malfunctions (the seat section is worn out or a foreign substance is mixed into the valve), the packing or similar part is damaged, or the shovel rod is bent.	Replace the malfunctioning part with a new one, or remove the foreign substance.
	If the plunger operates faster during the moving-down process, the pump operates at a speed too high for the lower pump to suck ink (the lower pump is evacuated).	Decrease the air pressure so that this phenomenon cannot occur (under this condition, the air pressure you set at this point is the upper limit the pump can operate at normally).
	The screw or other part that fix the air motor and the plunger of the lower pump is loosened, and then removed completely (a part located inside the lower pump may be damaged).	After checking the inside of the lower pump, replace the damaged part with a new one, and tighten the removed screw(s) securely.
The pump does not stop.	Ink leakage from the ink delivery pipe connection.	Tighten the screw fixed at the malfunctioning section further or replace the damaged part with a new one.
	Ink leakage from the parts-connecting section of the suction pump assembly.	
Air leakage form the air motor	The screws that connect parts is loosened, or the O-ring, packing or similar part is damaged.	Tighten the screw fixed at the malfunctioning section further, or replace the damaged part with a new one.
Air leakage from the silencer during stop	A foreign substance is caught between the block inside the switching valve (804355 or 804358) and the sliding section of the switching valve seat (705688), the seat is worn out, or the gasket (772331) is damaged.	Replace the damaged part with a new one, or remove the foreign substance.
Ink leakage from the suction pump	The screws that connect parts is loosened, or the O-ring, back-up ring, packing or other similar part is damaged.	Tighten the screw fixed at the malfunctioning section further, or replace the damaged part with a new one.
Air entrained in ink	The screws that connect parts of the lower pump is loosened, or the O-ring, back-up ring, or gasket is damaged.	Tighten the screw fixed at the malfunctioning section further, or replace the damaged part with a new one.
The oil container swells (is dissolved)	Without Overflow catch bottle.	Put in Overflow catch bottle, when you operate pump.
	Solvent attacks acrylic resin.	Use spindle oil (ISO viscosity grade 10).
The amount of liquid increases rapidly in the oil container.	The gland seal is worn out or damaged.	Replace the gland seal with a new one.

----- RETAIN THIS INFORMATION FOR FUTURE REFERENCE-----

For accurate and speedy shipment of parts, be sure to order the right parts for your model from your distributor. Indicate the part numbers, descriptions, and quantities.